



SPEED QUEEN® MULTI-HOUSING LAUNDRY SOLUTIONS

Single Tumble Dryer

ST030

30 lb (14 kg)

Built for Reliable Performance

Our single pocket tumble dryers are designed with fewer moving parts, so that you'll face fewer maintenance problems and less wear and tear.

- Feature an axial airflow process that ensures heated air comes in contact with load at the optimum time in tumble process
- High-performance burners ignite instantly, providing the desired temperature quickly and distributing heat evenly and efficiently

- Extra-large stainless steel doors and heavy-duty hinges ensure these machines will stand up to repeated use of high-traffic laundry rooms
- Feature an all-belt drive system, which means they're less noisy and less expensive to maintain
- Fine mesh lint screen is self-cleaning, depositing lint into a large storage area for easy, once-per-day removal

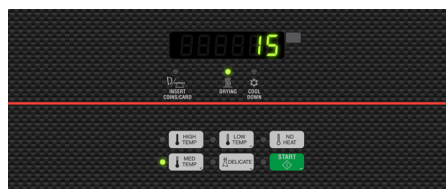

Quantum® Gold Control

Cutting edge Quantum® control system from Speed Queen® gives you the freedom to manage laundry your way and the power to achieve unmatched levels of revenue. This revolutionary technology provides users with more cycle choices than ever, offers unprecedented options to help lower operating costs and incorporates tools and options to increase revenue.

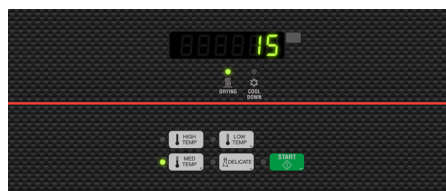

Micro Display II Control (MDC II)

The Micro Display Control II (MDC II) clearly displays the vend price and keeps customers informed throughout the drying process with cycle status lights and a digital cycle countdown. Interfacing with a variety of aftermarket card reader systems, MDC II offers four cycle selections and basic audit features.



Single Tumble Dryer

Specifications

		ST030	
Control Option		Quantum Gold, Micro Display II	
Capacity - lb (kg)		30 (13)	
Overall Width - in (mm)		27.9 (710)	
Overall Depth - in (mm)		45.5 (1155)	
Overall Height - in (mm)		63.9 (1625)	
Cylinder Diameter - in (mm)		26.5 (673)	
Cylinder Depth - in (mm)		30.0 (762)	
Cylinder Volume - cu. ft (liters)		9.6 (270)	
Reversing Cylinder		Standard	
Door Opening Size - in (mm)		22.7 (577)	
Heat Input Power		73,000 Btu/hr	
Gas Connections* - in (npt)		0.5	
Air Outlet - in (mm)		6 (152)	
Motor - HP		Fan	0.5
		Cylinder	0.3
Airflow - cfm		500	
Electrical Specs - amps	B	100-120V/50/60/1	10
	X	200-240V/50/60/1/3	6
Shipping Dimensions Approx.- in (mm)		Width	30.0 (762)
		Depth	49.0 (1245)
		Height	67.6 (1717)
Net Weight - lb (kg)		320 (145)	
Shipping Weight - lb (kg)		340 (155)	
Agency Approvals		CSA	

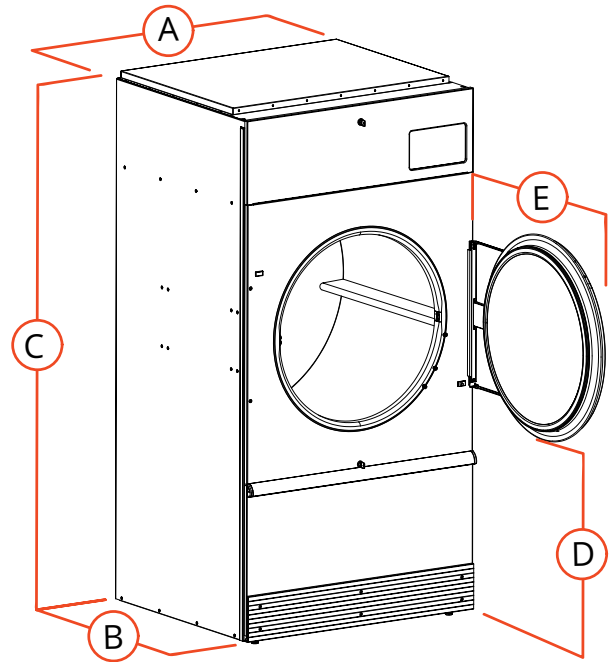

A.	Overall Width - in (mm)	27.9 (710)
B.	Overall Depth - in (mm)	45.5 (1155)
C.	Overall Height - in (mm)	63.9 (1625)
D.	Door Bottom to Floor - in (mm)	27.5 (700)
E.	Door Swing - in (mm)	26.3 (670)

* LP gas available for 50, 75 lb capacities only. Field conversion kits available for other capacities.

Tumble dryer models are made to suit a variety of electrical service characteristics. See your Speed Queen route operator for specifications.

For further details on installation, refer to Installation, Operation and Maintenance instructions supplied with the tumble dryer. Amperage ratings available in Installation Manual.

For the most accurate information, the installation guide should be used for all design and construction purposes. Due to continuous product improvements, design and specifications subject to change without notice. The quality management systems at Alliance Laundry Systems are registered to ISO 9001.



SPEED QUEEN® MULTI-HOUSING LAUNDRY SOLUTIONS

Single Tumble Dryer

ST035

35 lb (16 kg)

Built for Reliable Performance

Our single pocket tumble dryers are designed with fewer moving parts, so that you'll face fewer maintenance problems and less wear and tear.

- Feature an axial airflow process that ensures heated air comes in contact with load at the optimum time in tumble process
- High-performance burners ignite instantly, providing the desired temperature quickly and distributing heat evenly and efficiently

- Extra-large stainless steel doors and heavy-duty hinges ensure these machines will stand up to repeated use of high-traffic laundry rooms
- Feature an all-belt drive system, which means they're less noisy and less expensive to maintain
- Fine mesh lint screen is self-cleaning, depositing lint into a large storage area for easy, once-per-day removal

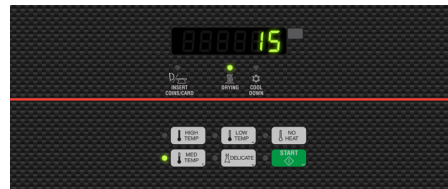

Quantum® Gold Control

Cutting edge Quantum® control system from Speed Queen® gives you the freedom to manage laundry your way and the power to achieve unmatched levels of revenue. This revolutionary technology provides users with more cycle choices than ever, offers unprecedented options to help lower operating costs and incorporates tools and options to increase revenue.

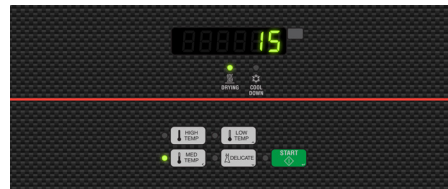

Micro Display II Control (MDC II)

The Micro Display Control II (MDC II) clearly displays the vend price and keeps customers informed throughout the drying process with cycle status lights and a digital cycle countdown. Interfacing with a variety of aftermarket card reader systems, MDC II offers four cycle selections and basic audit features.



Single Tumble Dryer

Specifications

		ST035	
Control Option		Quantum Gold, Micro Display II	
Capacity - lb (kg)		35 (16)	
Overall Width - in (mm)		31.5 (800)	
Overall Depth - in (mm)		45.5 (1155)	
Overall Height - in (mm)		63.9 (1625)	
Cylinder Diameter - in (mm)		30 (762)	
Cylinder Depth - in (mm)		30.0 (762)	
Cylinder Volume - cu. ft (liters)		12.3 (350)	
Reversing Cylinder		Standard	
Door Opening Size - in (mm)		22.7 (577)	
Heat Input Power		90,000 Btu/hr	
Gas Connections* - in (npt)		0.5	
Air Outlet - in (mm)		8 (200)	
Motor - HP		Fan	0.5
		Cylinder	0.3
Airflow - cfm		600	
Electrical Specs - amps	B	100-120V/50/60/1	10
	X	200-240V/50/60/1/3	6
Shipping Dimensions Approx.- in (mm)		Width	33.0 (838)
		Depth	49.0 (1245)
		Height	67.6 (1717)
Net Weight - lb (kg)		340 (155)	
Shipping Weight - lb (kg)		360 (165)	
Agency Approvals		CSA	

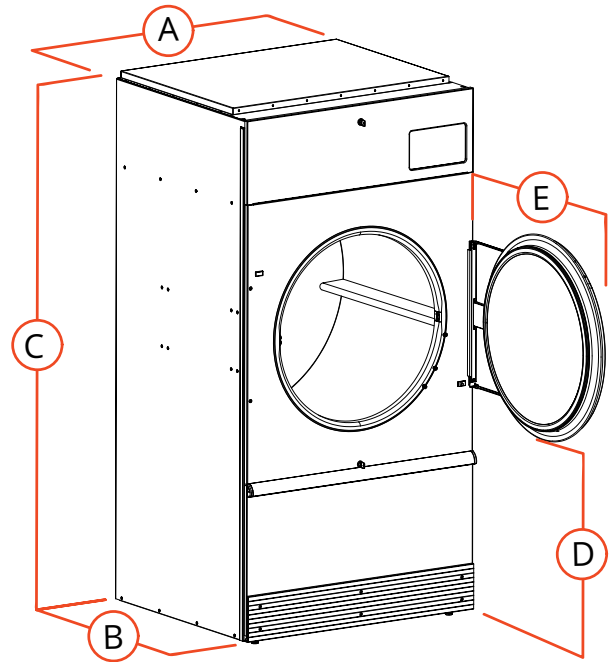

A.	Overall Width - in (mm)	31.5 (800)
B.	Overall Depth - in (mm)	45.5 (1155)
C.	Overall Height - in (mm)	63.9 (1625)
D.	Door Bottom to Floor - in (mm)	27.5 (700)
E.	Door Swing - in (mm)	26.3 (670)

* LP gas available for 50, 75 lb capacities only. Field conversion kits available for other capacities.

Tumble dryer models are made to suit a variety of electrical service characteristics. See your Speed Queen route operator for specifications.

For further details on installation, refer to Installation, Operation and Maintenance instructions supplied with the tumble dryer. Amperage ratings available in Installation Manual.

For the most accurate information, the installation guide should be used for all design and construction purposes. Due to continuous product improvements, design and specifications subject to change without notice. The quality management systems at Alliance Laundry Systems are registered to ISO 9001.



SPEED QUEEN® MULTI-HOUSING LAUNDRY SOLUTIONS

Single Tumble Dryer

ST050

50 lb (23 kg)

Built for Reliable Performance

Our single pocket tumble dryers are designed with fewer moving parts, so that you'll face fewer maintenance problems and less wear and tear.

- Feature an axial airflow process that ensures heated air comes in contact with load at the optimum time in tumble process
- High-performance burners ignite instantly, providing the desired temperature quickly and distributing heat evenly and efficiently



- Extra-large stainless steel doors and heavy-duty hinges ensure these machines will stand up to repeated use of high-traffic laundry rooms
- Feature an all-belt drive system, which means they're less noisy and less expensive to maintain
- Fine mesh lint screen is self-cleaning, depositing lint into a large storage area for easy, once-per-day removal

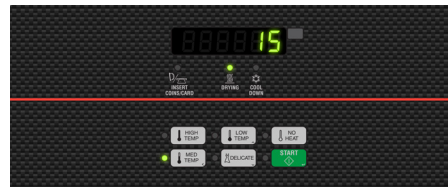

Quantum® Gold Control

Cutting edge Quantum® control system from Speed Queen® gives you the freedom to manage laundry your way and the power to achieve unmatched levels of revenue. This revolutionary technology provides users with more cycle choices than ever, offers unprecedented options to help lower operating costs and incorporates tools and options to increase revenue.

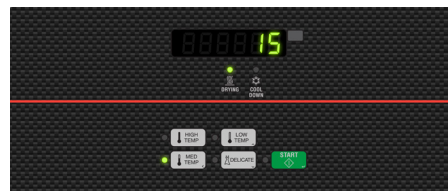

Micro Display II Control (MDC II)

The Micro Display Control II (MDC II) clearly displays the vend price and keeps customers informed throughout the drying process with cycle status lights and a digital cycle countdown. Interfacing with a variety of aftermarket card reader systems, MDC II offers four cycle selections and basic audit features.

Single Tumble Dryer

Specifications

		ST050	
Control Option		Quantum Gold, Micro Display II	
Capacity - lb (kg)		50 (23)	
Overall Width - in (mm)		38.5 (978)	
Overall Depth - in (mm)		46.8 (1189)	
Overall Height - in (mm)		77.3 (1963)	
Cylinder Diameter - in (mm)		37.0 (940)	
Cylinder Depth - in (mm)		30.0 (762)	
Cylinder Volume - cu. ft (liters)		18.7 (530)	
Reversing Cylinder		Standard	
Door Opening Size - in (mm)		26.9 (683)	
Heat Input Power		122,000 Btu/hr	
Gas Connections* - in (npt)		0.5	
Air Outlet - in (mm)		8 (203)	
Motor - HP		Fan	0.5
		Cylinder	0.5
Airflow - cfm		700	
Electrical Specs - amps	B	100-120V/50/60/1	9
	X	200-240V/50/60/1/3	6
Shipping Dimensions Approx.- in (mm)		Width	41.5 (1054)
		Depth	50.0 (1270)
		Height	81.0 (2057)
Net Weight - lb (kg)		660 (299)	
Shipping Weight - lb (kg)		710 (322)	
Agency Approvals		CSA	

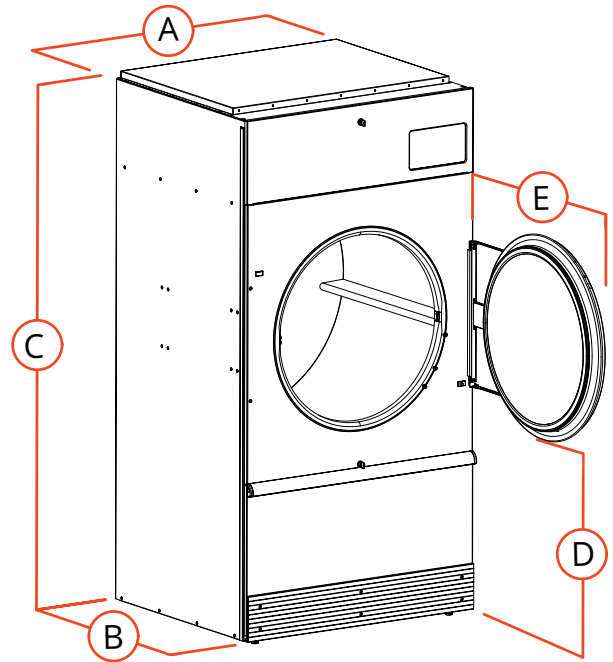

A.	Overall Width - in (mm)	38.5 (978)
B.	Overall Depth - in (mm)	46.8 (1189)
C.	Overall Height - in (mm)	77.3 (1963)
D.	Door Bottom to Floor - in (mm)	29.2 (740)
E.	Door Swing - in (mm)	33.9 (860)

* LP gas available for 50, 75 lb capacities only. Field conversion kits available for other capacities.

Tumble dryer models are made to suit a variety of electrical service characteristics. See your Speed Queen route operator for specifications.

For further details on installation, refer to Installation, Operation and Maintenance instructions supplied with the tumble dryer. Amperage ratings available in Installation Manual.

For the most accurate information, the installation guide should be used for all design and construction purposes. Due to continuous product improvements, design and specifications subject to change without notice. The quality management systems at Alliance Laundry Systems are registered to ISO 9001.



SPEED QUEEN® MULTI-HOUSING LAUNDRY SOLUTIONS

Single Tumble Dryer

ST055

55 lb (25 kg)

Built for Reliable Performance

Our single pocket tumble dryers are designed with fewer moving parts, so that you'll face fewer maintenance problems and less wear and tear.

- Feature an axial airflow process that ensures heated air comes in contact with load at the optimum time in tumble process
- High-performance burners ignite instantly, providing the desired temperature quickly and distributing heat evenly and efficiently



- Extra-large stainless steel doors and heavy-duty hinges ensure these machines will stand up to repeated use of high-traffic laundry rooms
- Feature an all-belt drive system, which means they're less noisy and less expensive to maintain
- Fine mesh lint screen is self-cleaning, depositing lint into a large storage area for easy, once-per-day removal

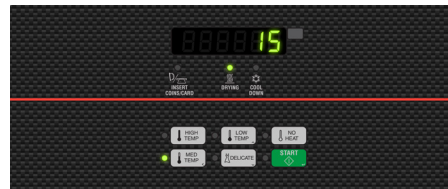

Quantum® Gold Control

Cutting edge Quantum® control system from Speed Queen® gives you the freedom to manage laundry your way and the power to achieve unmatched levels of revenue. This revolutionary technology provides users with more cycle choices than ever, offers unprecedented options to help lower operating costs and incorporates tools and options to increase revenue.

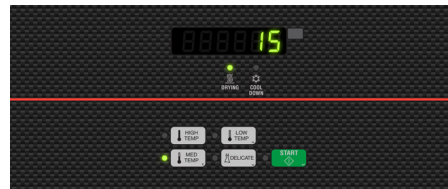

Micro Display II Control (MDC II)

The Micro Display Control II (MDC II) clearly displays the vend price and keeps customers informed throughout the drying process with cycle status lights and a digital cycle countdown. Interfacing with a variety of aftermarket card reader systems, MDC II offers four cycle selections and basic audit features.

Single Tumble Dryer

Specifications

		ST055	
Control Option		Quantum Gold, Micro Display II	
Capacity - lb (kg)		55 (25)	
Overall Width - in (mm)		34.5 (876)	
Overall Depth - in (mm)		53.1 (1349)	
Overall Height - in (mm)		66.7 (1694)	
Cylinder Diameter - in (mm)		33 (838)	
Cylinder Depth - in (mm)		35.0 (889)	
Cylinder Volume - cu. ft (liters)		17.3 (490)	
Reversing Cylinder		Standard	
Door Opening Size - in (mm)		26.9 (683)	
Heat Input Power		112,000 Btu/hr	
Gas Connections* - in (npt)		0.5	
Air Outlet - in (mm)		8 (200)	
Motor - HP		Fan	0.5
		Cylinder	0.5
Airflow - cfm		700	
Electrical Specs - amps	B	100-120V/50/60/1	12
	X	200-240V/50/60/1/3	7
Shipping Dimensions Approx.- in (mm)		Width	35.5 (902)
		Depth	57 (1448)
		Height	70.5 (1791)
Net Weight - lb (kg)		430 (195)	
Shipping Weight - lb (kg)		470 (213)	
Agency Approvals		CSA	

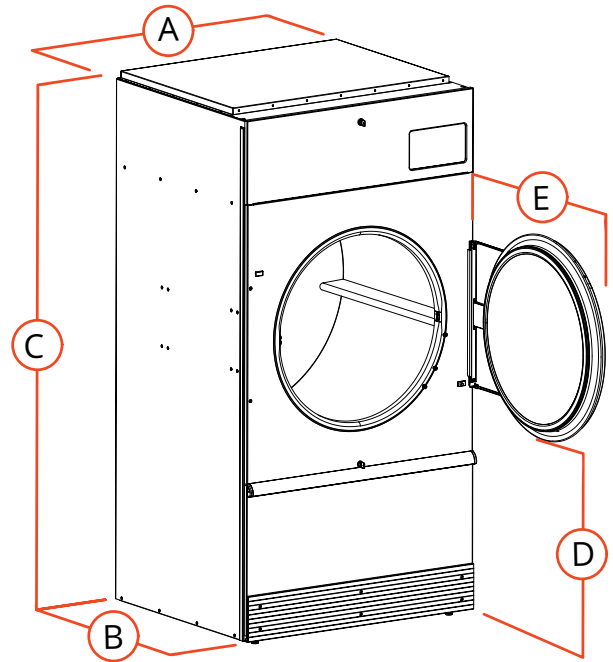

A.	Overall Width - in (mm)	34.5 (876)
B.	Overall Depth - in (mm)	53.1 (1349)
C.	Overall Height - in (mm)	66.7 (1694)
D.	Door Bottom to Floor - in (mm)	26.9 (683)
E.	Door Swing - in (mm)	31.9 (810)

* LP gas available for 50, 75 lb capacities only. Field conversion kits available for other capacities.

Tumble dryer models are made to suit a variety of electrical service characteristics. See your Speed Queen route operator for specifications.

For further details on installation, refer to Installation, Operation and Maintenance instructions supplied with the tumble dryer. Amperage ratings available in Installation Manual.

For the most accurate information, the installation guide should be used for all design and construction purposes. Due to continuous product improvements, design and specifications subject to change without notice. The quality management systems at Alliance Laundry Systems are registered to ISO 9001.



SPEED QUEEN® MULTI-HOUSING LAUNDRY SOLUTIONS

Single Tumble Dryer

ST075

75 lb (34 kg)

Built for Reliable Performance

Our single pocket tumble dryers are designed with fewer moving parts, so that you'll face fewer maintenance problems and less wear and tear.

- Feature an axial airflow process that ensures heated air comes in contact with load at the optimum time in tumble process
- High-performance burners ignite instantly, providing the desired temperature quickly and distributing heat evenly and efficiently

- Extra-large stainless steel doors and heavy-duty hinges ensure these machines will stand up to repeated use of high-traffic laundry rooms
- Feature an all-belt drive system, which means they're less noisy and less expensive to maintain
- Fine mesh lint screen is self-cleaning, depositing lint into a large storage area for easy, once-per-day removal

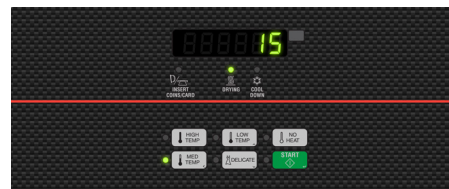
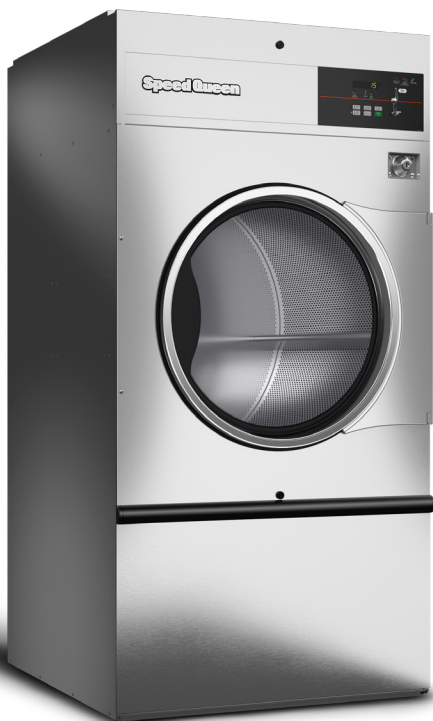

Quantum® Gold Control

Cutting edge Quantum® control system from Speed Queen® gives you the freedom to manage laundry your way and the power to achieve unmatched levels of revenue. This revolutionary technology provides users with more cycle choices than ever, offers unprecedented options to help lower operating costs and incorporates tools and options to increase revenue.

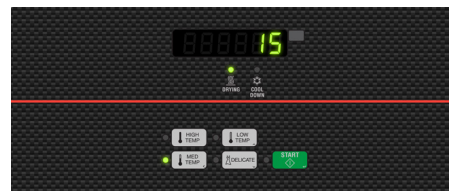

Micro Display II Control (MDC II)

The Micro Display Control II (MDC II) clearly displays the vend price and keeps customers informed throughout the drying process with cycle status lights and a digital cycle countdown. Interfacing with a variety of aftermarket card reader systems, MDC II offers four cycle selections and basic audit features.

Single Tumble Dryer

Specifications

		ST075	
Control Option		Quantum Gold, Micro Display II	
Capacity - lb (kg)		75 (34)	
Overall Width - in (mm)		38.5 (978)	
Overall Depth - in (mm)		53.0 (1346)	
Overall Height - in (mm)		77.3 (1963)	
Cylinder Diameter - in (mm)		37.0 (940)	
Cylinder Depth - in (mm)		36.0 (914)	
Cylinder Volume - cu. ft (liters)		22.4 (634)	
Reversing Cylinder		Standard	
Door Opening Size - in (mm)		26.9 (683)	
Heat Input Power		150,000 Btu/hr	
Gas Connections* - in (npt)		0.5	
Air Outlet - in (mm)		8 (200)	
Motor - HP		Fan	0.5
		Cylinder	0.5
Airflow - cfm		800	
Electrical Specs - amps	B	100-120V/50/60/1	12
	X	200-240V/50/60/1/3	7
Shipping Dimensions Approx.- in (mm)		Width	41.5 (1054)
		Depth	56.0 (1422)
		Height	81.0 (2057)
Net Weight - lb (kg)		690 (313)	
Shipping Weight - lb (kg)		740 (336)	
Agency Approvals		CSA	

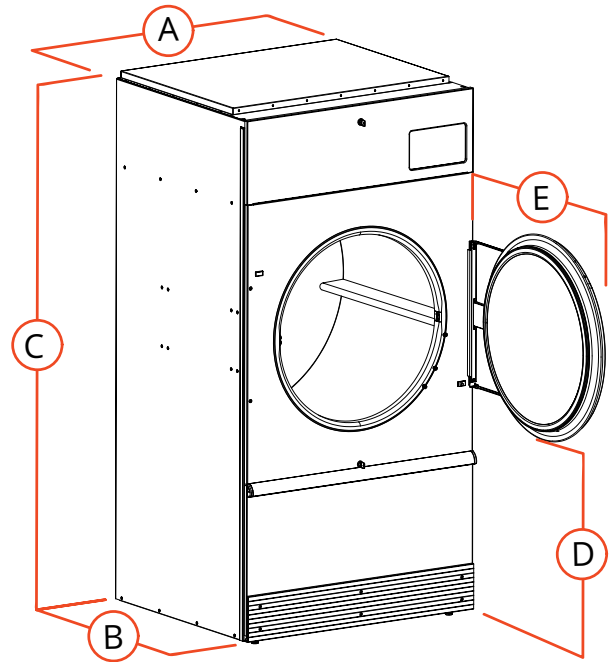

A.	Overall Width - in (mm)	38.5 (978)
B.	Overall Depth - in (mm)	53.0 (1346)
C.	Overall Height - in (mm)	77.3 (1963)
D.	Door Bottom to Floor - in (mm)	29.2 (740)
E.	Door Swing - in (mm)	33.9 (860)

* LP gas available for 50, 75 lb capacities only. Field conversion kits available for other capacities.

Tumble dryer models are made to suit a variety of electrical service characteristics. See your Speed Queen route operator for specifications.

For further details on installation, refer to Installation, Operation and Maintenance instructions supplied with the tumble dryer. Amperage ratings available in Installation Manual.

For the most accurate information, the installation guide should be used for all design and construction purposes. Due to continuous product improvements, design and specifications subject to change without notice. The quality management systems at Alliance Laundry Systems are registered to ISO 9001.