

SPEED QUEEN® MULTI-HOUSING LAUNDRY SOLUTIONS

# Commercial Front Load Washers

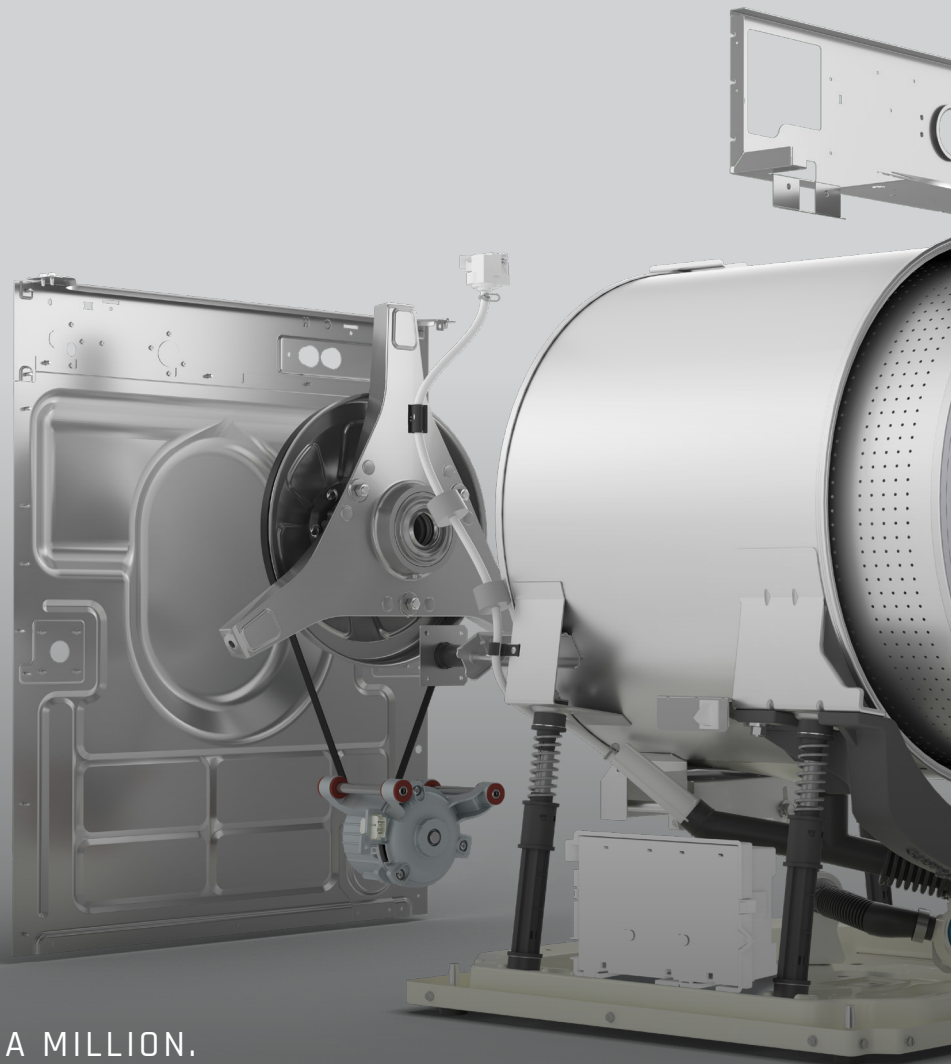



TRUE REVOLUTION IS ONE IN A MILLION.

# Meet The One.

At Speed Queen®, we're constantly pushing the boundaries of what's possible in laundry equipment. Through our unique five-step product development process, including rigorous testing that guarantees superior industrial quality, our focus on innovation and technology is changing the way our customers think about laundry. And never has this dedication to advancing our industry manifested in anything more revolutionary than the Speed Queen® front load washer.



Engineered and built like no other, the Speed Queen® front load washer is designed to be everything people thought a washer couldn't be, beginning with its revolutionary new suspension and sensing technology. This groundbreaking innovation manages and redistributes any and all out-of-balance loads to deliver uninterrupted cycles, virtually eliminate vibration and operate so quietly neighboring residents won't even know it's running. It also touts an incredible 440 G-Force extraction speed to maximize moisture removal, reduce dry times and minimize utility costs. And as if that's not game-changing enough, this smooth-running, laundry-optimizing machine delivers increased water efficiency and a redesigned, 10-degree tilted control panel for easier readability and the ultimate user experience. It's everything you never knew it could be.

## FRONT LOAD WASHERS

# Everything You Ever Wanted.

### Larger door opening

15.5" diameter and a 180° door swing help customers quickly load and unload the machine.

### 4-Compartment soap dispenser

Redesigned soap dispenser on Quantum® models offers compartments for pre-wash detergent, wash detergent, bleach and fabric softener.

### Improved dispenser flushing

Four times more flushing and siphoning delivers superior cleaning of dispenser, reducing the need for ongoing maintenance and cleaning.

### 30% Larger coin box

Larger integrated coin box on front control machines reduces the time you spend collecting coins. Coin and card capable.

### Heavy-duty design

Features like a rugged suspension system and stainless steel washtub and outer drain combine to deliver long-lasting performance.





And Everything You  
Never Knew it Could Be.



### Revolutionary balancing technology

Speed Queen® front load washers introduce improved out-of-balance technology that uses a redesigned suspension and advanced sensing logic to manage and redistribute out-of-balance loads, delivering smooth, uninterrupted wash cycles every time.

---



### 2.5 Times less noise

Speed Queen's® solid design significantly reduces vibration and noise without sacrificing spin speed or cycle times, minimizing the negative effects your laundry has on neighboring residents.

---



### Incredible 440 G-Force extraction

We increased our already industry-leading extraction speed to even further maximize moisture removal and minimize dry times, something your residents will appreciate as much as your bottom line.

---



### Improved efficiency

Speed Queen® front load washers have 20 percent more capacity than previous models while only increasing water usage by six percent, delivering better efficiency overall while offering the same premium wash quality. The result is heightened customer satisfaction without a significant impact on utilities.

---



### 10° Tilted control panel

Speed Queen® front load washer control panels are angled ten degrees up toward the user's line of sight, allowing for easy readability without the need to bend down—a small change that makes a big impact on residents.

---



### Patent-pending baffles

These revolutionary baffles feature a patent-pending design that lifts and cascades water throughout the entire load, delivering the absolute best quality wash.



SPEED QUEEN® MULTI-HOUSING LAUNDRY SOLUTIONS  
**Front Control Front Load Washer**

**Quantum® Gold Pro**

Prep for Card | Coin Drop Installed

**Built for Reliable Performance**

Engineered and built like no other, the Speed Queen® front load washer is designed to be everything people thought a washer couldn't be, beginning with its revolutionary suspension and sensing technology. This groundbreaking innovation manages and redistributes out-of-balance loads to deliver uninterrupted cycles, virtually eliminate vibration and operate so quietly neighboring residents won't even know it's running. It also touts an incredible 440 G-Force extraction speed to maximize moisture removal, reduce dry times and minimize utility costs. And as if that's not game-changing enough, this smooth-running, laundry-optimizing machine delivers increased water efficiency. It's everything you never knew it could be. Front controlled products have met every design standard to be 100% ADA compliant.

- Revolutionary balancing technology
- Industry leading 1200 RPM spin speed exerts 440 G-force extraction
- Integrated meter case
- Extra-wide 15.5" door opening and 180° door swing
- Rugged suspension system
- Easy-to-read digital display
- Large capacity meter case standard
- Multi-level vend pricing
- Individual cycle modifier keys
- Durable stainless steel tub standard
- Four-compartment soap dispenser
- Wash Alert™ capability



**Quantum® Gold Pro Control**

The Quantum® Gold Pro control delivers a truly premium experience to residents. From intuitive soft touch buttons that walk them through cycle options to multiple actuations (coin, card, mobile) for payment flexibility, this control gives residents the wash and dry options they want, and the revenue potential managers desire.

# Front Control Front Load Washer

## Quantum® Gold Pro

Specifications		
Control Option	Quantum Gold Pro	
Color	White	
Capacity - lb (kg)	21.5 (9.5)	
Overall Width - in (mm)	26.875 (683)	
Overall Depth - in (mm)	27.73 (704)	
Overall Height - in (mm)	44.34 (1126)	
Cylinder Volume - cu. ft. (liters)	3.42 (96.8)	
Spin Speed G-Force (RPM)	440 (1200)	
Motor Size - HP (kw)	0.9 (0.67)	
Water Consumption Per Cycle - g (liter)**	13.68 (51.8)	
IWF (Water Factor) - gal/ft <sup>3</sup> (liters/liter/cycle)**	4.0 (0.53)	
MEF <sub>j2</sub> (Modified Energy Factor) ft <sup>3</sup> /kWh/cycle (Liters/kWh/cycle)**	2.20 (62.3)	
Available Water Temperatures	Cold, Warm, Hot	
Available Cycles	Normal, Synthetic, Delicate	
Electrical Requirements (v/Hz/Ph-Amp)	120/60/1 - 15 Amp	
Water Pressure - p.s.i. (bar)	20-120 (1.4/8.3)	
Cylinder Finish	Stainless Steel	
Net Weight - lb (kg)	260 (118)	
Shipping Weight - lb (kg)	270 (122.5)	
Shipping Dimensions Approx. - in (mm)	Width	34 (864)
	Depth	30 (762)
	Height	44.5 (1130)
Agency Approvals	cULus	

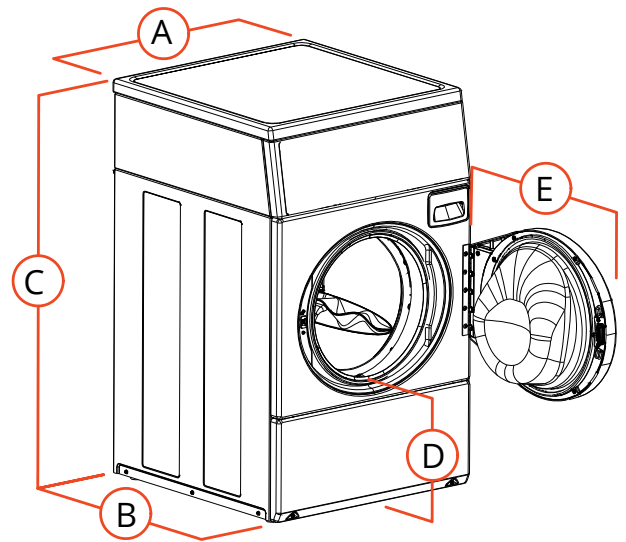

A. Overall Width - in (mm)	26.875 (683)
B. Overall Depth - in (mm)	27.73 (704)
C. Overall Height - in (mm)	44.34 (1126)
D. Floor To Door Opening -in (mm)	14.6 (371)*
E. Door Swing - in (mm)	24 (610)

\* For ADA compliance turn legs out from base 0.5 inches

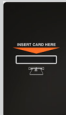
Models	Drain	Actuation
SFNNCASP116TW01	Pump	Coin Drop Installed 
SFNNCASG116TW01	Gravity	
SFNNYASP116TW01	Pump	Prep for Card 
SFNNYASG116TW01	Gravity	

Supply inject kits available.

\*\* Average usage based on multiple load sizes and current DOE test protocol. Real usage will vary depending on load size, composition and cycle selectivity.

For the most accurate information, the installation guide should be used for all design and construction purposes. Due to continuous product improvements, design and specifications subject to change without notice. The quality management systems at Alliance Laundry Systems are registered to ISO 9001.